

WARPING EFFECT IN A STEEL BOX GIRDER BRIDGE STRUCTURE

Trong Chuc Nguyen¹, Ba Thang Phung²

¹ Le Quy Don Technical University, Hanoi 100000, VIETNAM

² University of Transport Technology, Hanoi 100000, VIETNAM

Abstract: In recent years, the construction of steel box girder bridges has become a widespread and standard practice in many major cities across Vietnam. These types of bridges are favored due to their structural strength, durability, and ability to accommodate modern traffic demands. Despite their increasing use, one important aspect often overlooked in current research is the distortion that occurs in the cross-sections of steel box girders, particularly during buckling. This distortion can significantly affect the structural performance and safety of the bridge over time. To address this research gap, this study focuses on analyzing how three critical factors—the size of the cross-section, the type of longitudinal link used, and the distance between longitudinal links—affect the buckling deformation behavior of steel box beam cross-sections. The analysis is conducted using the finite element method (FEM), a powerful simulation tool that enables detailed modeling of structural behavior under load. Through a series of simulations and evaluations, the study reveals that these parameters have a substantial influence on the deformation patterns and overall stability of the steel box girder. The results of this research contribute valuable insights that can assist engineers in designing more efficient and safer steel box bridges. Furthermore, the findings serve as a useful technical reference for current and future bridge design projects in Vietnam, helping to enhance both design standards and construction practices across the country's transportation infrastructure.

Keywords: Warping the section, steel box bridges, girder bridge, deformation, torsion

ЭФФЕКТ КОРОБЛЕНИЯ В КОНСТРУКЦИИ МОСТА С КОРОБЧАТОЙ СТАЛЬНОЙ БАЛКОЙ

Нгуен Чонг Чык¹, Пхунг Ба Тханг²

¹ Вьетнамский государственный технический университет имени Ле Куи Дона, Ханой 100000, ВЬЕТНАМ

² Университет транспортных технологий, Ханой 100000, ВЬЕТНАМ

Аннотация: В последние годы строительство мостов с коробчатыми стальными балками стало широко распространённой и стандартной практикой во многих крупных городах Вьетнама. Эти типы мостов пользуются популярностью благодаря своей высокой прочности, долговечности и способности удовлетворять требованиям современного транспортного движения. Несмотря на растущую распространённость таких конструкций, в существующих исследованиях часто упускается из виду один важный аспект — деформации, возникающие в поперечном сечении коробчатых балок, особенно при потере устойчивости (буртообразовании). Эти искажения могут существенно повлиять на несущую способность и безопасность мостовой конструкции в процессе эксплуатации. С целью восполнения данного научного пробела в настоящем исследовании проводится анализ влияния трёх ключевых факторов — размеров поперечного сечения, типа продольных связей и расстояния между ними — на поведение коробчатых стальных балок при потере устойчивости. Анализ осуществляется с использованием метода конечных элементов (МКЭ), который представляет собой мощный инструмент численного моделирования напряжённо-деформированного состояния конструкций под действием нагрузки. В результате серии численных экспериментов установлено, что указанные параметры оказывают значительное влияние на форму деформации и общую устойчивость коробчатых балок. Полученные результаты представляют собой ценный вклад в проектирование более эффективных и безопасных мостов с коробчатыми стальными балками. Кроме того, они могут служить надёжной технической основой для текущих и будущих проектов мостового строительства во Вьетнаме, способствуя улучшению проектных норм и строительных практик в транспортной инфраструктуре страны.

Ключевые слова: Деформация сечения, стальные коробчатые мосты, балочные мосты, деформация, кручение

INTRODUCTION

Although Hanoi and Ho Chi Minh City in Vietnam have many steel bridges, there have been few domestic studies on how these structures function, particularly their effectiveness and response to warping in the cross-section of steel beams. Steel bridges' primary cross-sections are the I-section and the box-section. Intersections are bridges with a lot of torque when used on curved bridges, and the steel box girder bridge has the advantage of torsion stiffness. Depending on the width of the deck, the cross-section of a steel box girder bridge can take the form of a single box, several individual boxes, or a box with multiple partitions [1-3].

Bridge decks, reinforced concrete slabs combined with steel beams, and orthogonal slab decks are the most common types of steel bridges. Shear studs (Shear Stud) connect the reinforced concrete slab deck to the steel beams. Large bridges use steel orthogonal slab structures to reduce deck static load and save materials. The orthogonal slab functions as a deck slab as well as a main girder component. Because the orthogonal plate connects the main beam branches, the upper longitudinal connection system can be removed [4].

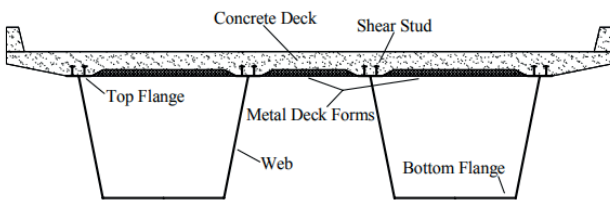

Figure 1. Cross section of steel box beam [4]

The bottom slab (Bottom Flange), web, top flange, and reinforced concrete deck (concrete deck) are the basic components of a composite steel box girder bridge shown in the cross-section. The bridge's box-shaped cross-section was closed. Anchor connection (Shear Stud) to ensure the unity of the steel beam and the reinforced concrete slab against sliding force and separation (Figure 1) [4-6].

The vertical and horizontal connection systems are both components of the box girder bridge's connection system. Figure 2.a depicts the internal

bracing system as a K-frame. The connection system regulates the warping deformation of the box girder. Because of the shape of this K-frame connection system, it is easy to travel inside the box during construction or inspection while in use. The upper wing of the beam should have the truss form shown in Figure 2.b to control torsion during construction and erection [4].

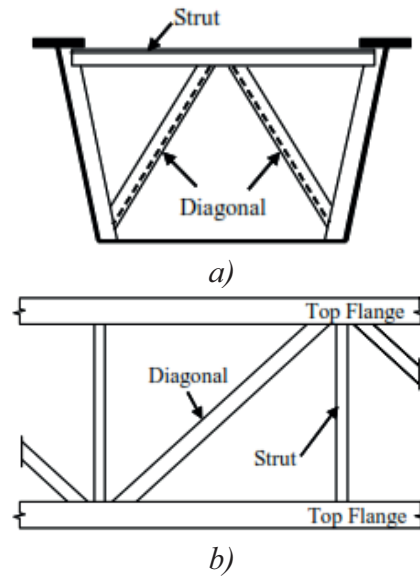

Figure 2. Typical connection system in steel box girder bridges [4]

The combined steel box girder solution satisfies the aforementioned criteria with exceptional benefits in span, high torsional stiffness, high aesthetics, durability, and good maintainability. The steel box girder is better for longer spans than the I-beam because it has higher flexural strength. The actual span is roughly 45-100m. This structure's span is 160 meters (Kanawha River bridge in Virginia state - USA). Because the steel box girder's structural form is more intricate than the I-beam's, manufacturing and installation of one call for highly skilled labor. Additionally, the weight of each steel box girder unit is typically higher than that of an I-beam, increasing the cost of construction. However, when compared to the I-beam span system, the steel box girder span system uses fewer main girders, transverse beams, and bracing systems, which lowers manufacturing costs as well as site labor costs. The characteristic of this type of beam is its high torsional rigidity,

so it is very suitable for curved bridges in intersections and ramps. Two bridges built in the US have a very small curvature of 45m (in the state of Massachusetts-1960) and 55m (the airport jetty at Dallas-1970). In contrast to other types of bridges, however, it should be noted that manufacturing vertical, horizontal, extremely high, and diagonal bridges can be challenging. Aesthetics are a notable benefit of steel box girder bridges. The bracing system, reinforcing ribs, utilities, and other components are "hidden" in the box, not being exposed and causing "distractions," while minimizing the risk of dust and dirt. This is in contrast to the integrated I-beam bridge. The direct corrosive effects of the environment are because they are "protected" inside the box, which lowers the cost of the coating system and makes it easy to conduct inspection and maintenance work inside the box [7].

system of 10 m connecting the two beam ribs is modeled and analyzed (Figure 3).

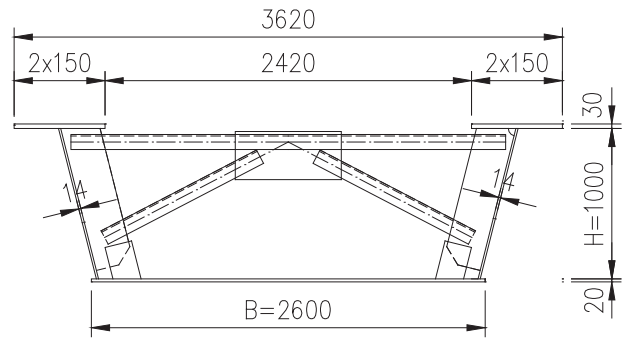

Figure 3. Cross-section of the steel box beam surveyed

Steel according to ASTM standards, elastic modulus $E= 1.9995 \text{ kN/m}^2$; Poisson's coefficient is 0.3; thermal expansion coefficient is 1.17×10^{-5} ; specific gravity is 77.09 kN/m^3 .

METHODS

Research subjects

A steel beam structure with a span length of $l = 50 \text{ m}$, a height of $H = 1 \text{ m}$, a bottom plate width of beam B varying from 1.6 m to 4.6 m, and a box beam with a spaced horizontal connection

Working characteristics of steel box girder bridge.

Consider the cross-section of the eccentrically loaded box-shaped steel box girder P , which is analyzed into bending and torsion components (Figure 4) [8, 9].

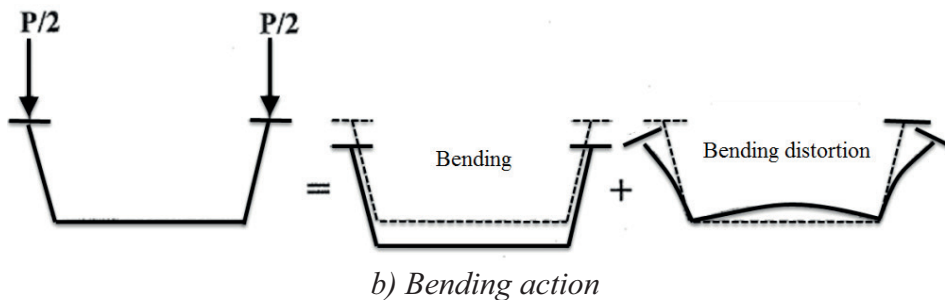
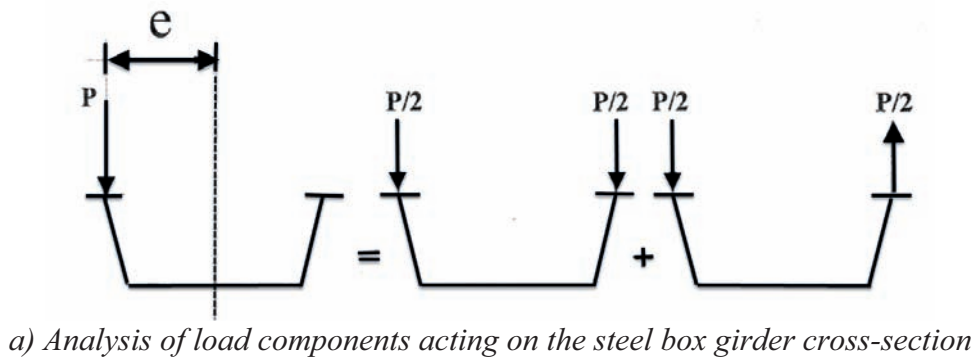

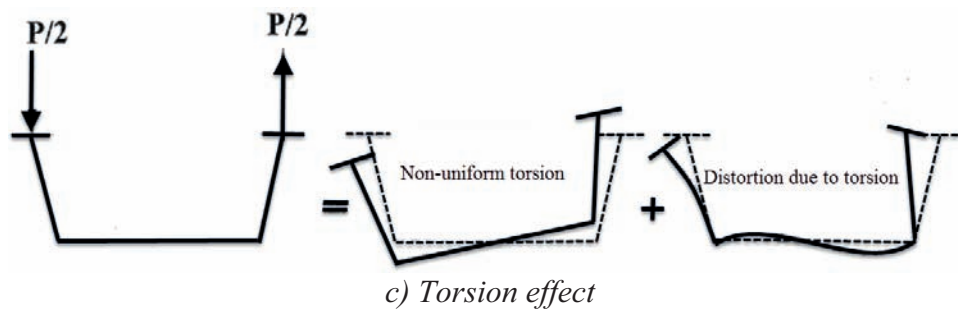

Figure 4. Analysis of load components P in open box girders according to the co-operative principle [10,11]

Bending loads can warp and buckle sections (Figure 4.b). When impact loads are applied to beams, a common phenomenon known as longitudinal bending takes place. The cross-section is frequently assumed to always be flat when performing the calculation. When loads are applied to open boxes, deformation occurs. This distortion leads to bending in the ribs, lower flange, and upper flange of open box girders. The cross-sectional shape of the slabs is altered by the out-of-plane bending of the beams that make up the slabs. For this reason, investigating the displacement of points on the cross-section will produce conclusive findings about the phenomenon [12, 13].

The torsional load was induced on the section (Figure 4.c). Due to the curvature of the bridge, lateral loads acting on a box girder cause torsion with the girder's longitudinal axis. The cross-section is frequently assumed to always be flat when performing the calculation. Steel plates are bent and their cross-sections are deformed by torsion. In order to clearly see the effects of this phenomenon, one should study the displacement of points on the cross-section [14,15].

Numerical method for determining the stress and strain states of steel box girders.

The finite element method is the most popular numerical approach. With this technique, large, complex engineering problems can be solved quickly and accurately as needed. By using this technique, the texture is discretized into finite elements, linked by nodes, and supported by boundary and continuity conditions, among other conditions. Unknowns regarding

Deformation and displacement at the nodes are the structural issue. Create differential equations by using fundamental mechanical principles, such as the energy principle, the virtual displacement principle, etc. This method is now available in commercial structural calculation programs like Midas, RM, Sap, Ansys, Abaqus, etc. that are frequently used in bridge construction. The elements used in the method include single-dimensional elements such as beams and bars as well as two-dimensional elements such as plates, shells, and solids (Figures 5, 6) [16-18].

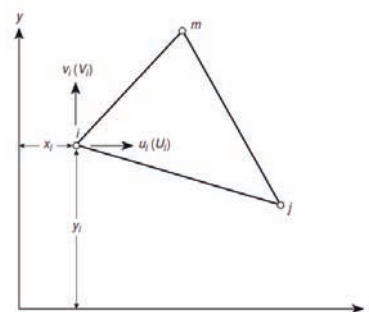

Figure 5. Plate element

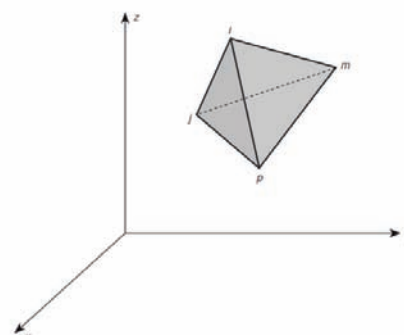

Figure 6. Solid element

The finite element method is regarded as a contemporary, all-encompassing approach that is currently widely used. It has demonstrated its benefits in quickly providing solutions to large-scale, complex problems. If using bar elements (6 degrees of freedom per node), the analysis will not clearly demonstrate the phenomenon of warping as well as distortion of the section based on the operation of curved steel box girders and the above-presented stress calculation formula. Therefore, the topic will

analyze in detail the steel box girder structure using the plate element by the finite element method [19, 20].

RESULTS AND DISCUSSION

Effect of cross-sectional dimensions on section warping. Modeling of the steel box girder section with nodes on the cross section is shown in Figure 7.

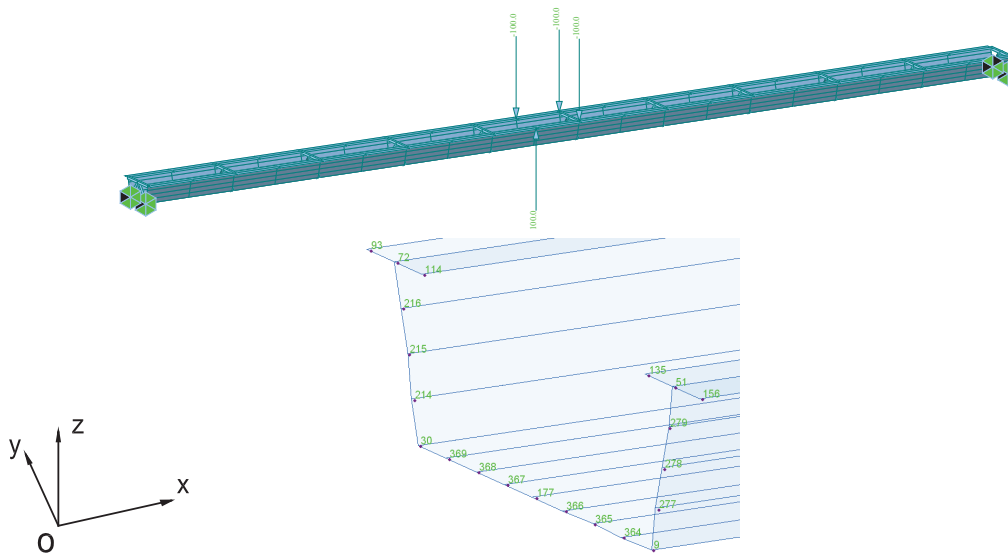

Figure 7. Modeling the box girder segment and the nodes on the cross-section

Surveying the width of the beam bottom plate (B) varies from 1.6m to 4.6m, the deformation

results of the nodes on the beam cross section are shown in Figure 8.

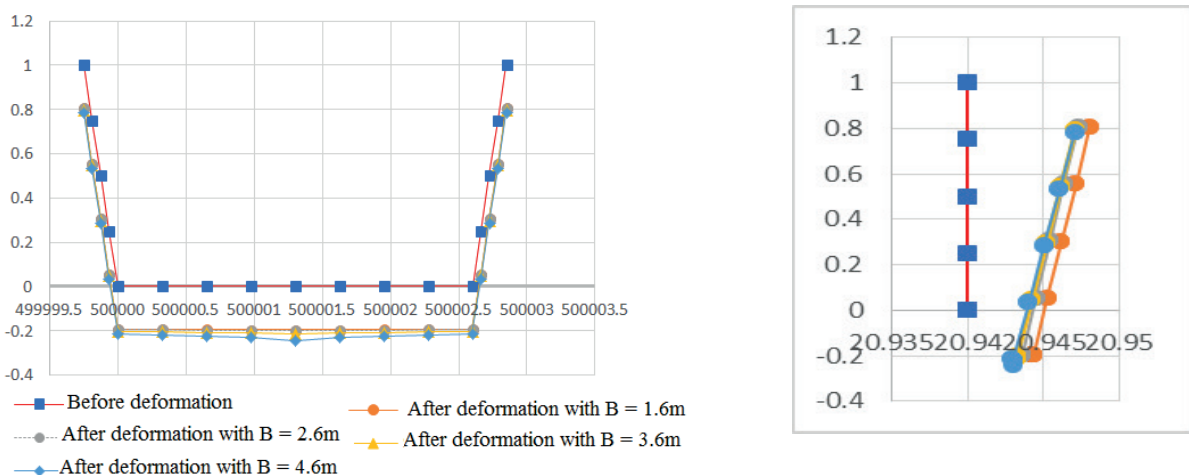

Figure 8. Deformation due to self-load: a) deformation in the y-z plane; b) deformation in the x direction

Figure 8 shows the deformation of the steel box girder cross-section due to the self-load. Figure 8.a shows the deformation in the y-z plane (the view is opposite to the x-axis). Figure 8.b shows the deformation in the x direction due to the change of cross section. Obviously, the

deformation in the y-z plane under the effect of self-load reaches the maximum when the width of the beam bottom plate $B = 4.6\text{m}$. Besides, the deformation in the x direction is greatest when the width of the beam bottom plate $B = 1.6\text{m}$.

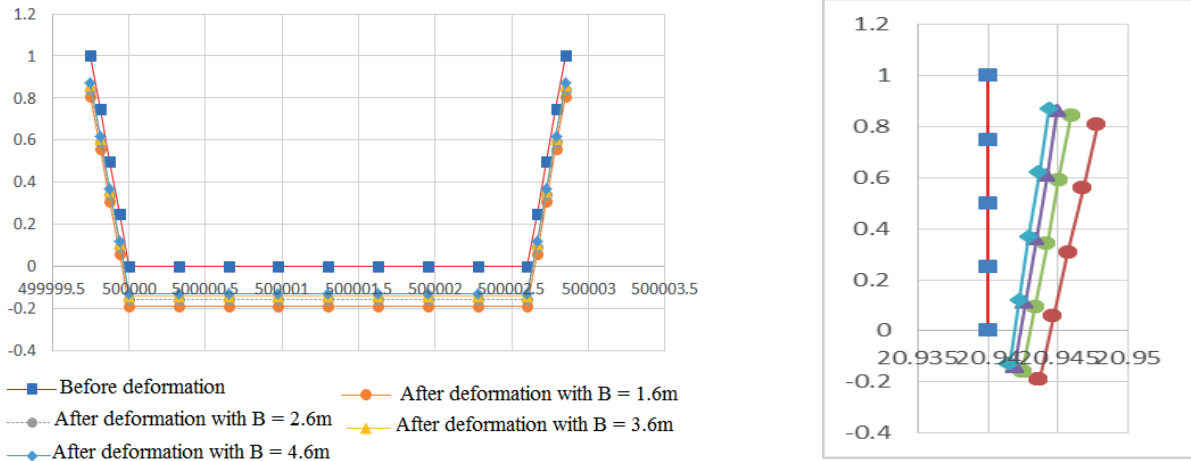

Figure 9. Cross-sectional deformation of steel box girder under symmetrical load: a) deformation in the y-z plane; b) deformation in the x direction

Figure 9 shows the deformation of the steel box girder cross-section under the application of symmetrical concentrated loads. Figure 9.a shows the deformation change in the y-z plane (the view is opposite to the x-axis). Figure 9.b shows the change of deformation in the x

direction due to the change in cross section of the steel box girder. From Figure 9, we can see that the deformation of the cross-section in the y-z plane and in the x direction reaches the maximum value when the width of the beam bottom plate $B = 1.6\text{m}$.

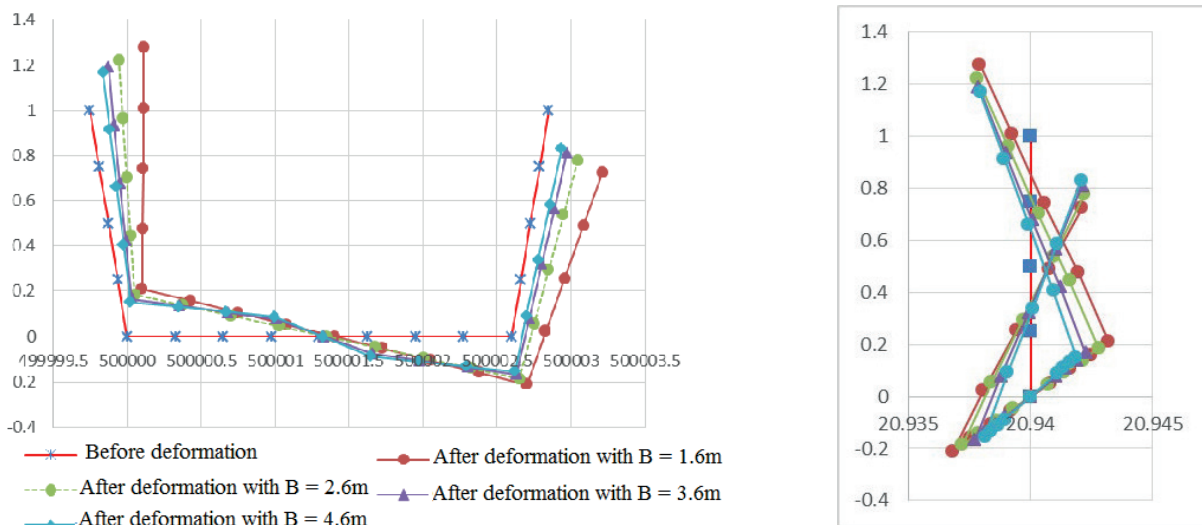

Figure 10. Cross-sectional deformation of steel box girder due to eccentric load: a) deformation in the y-z plane; b) deformation in the x direction

Figure 10 depicts the displacement change of the steel box girder cross-section due to eccentric load when the width of the beam bottom plate is changed. The results show that the displacement of the cross sectional nodes is significantly affected by the width of the beam bottom plate.

Effect of distance of steel box girder cross-linking system on section warping.

Look into how the steel box girder's cross-section warps in relation to the cross-linking system.

Consider the case with and without cross-linking of steel box girders. When using a cross-linking system, the distance between them varies from 2.5m to 7.5m and as shown in Figure 11.

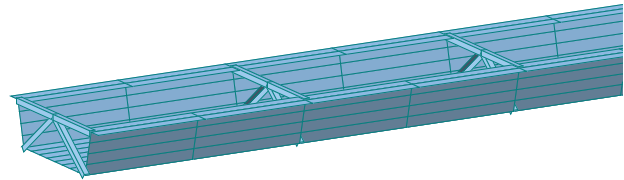

Figure 11. Cross-linked beam model

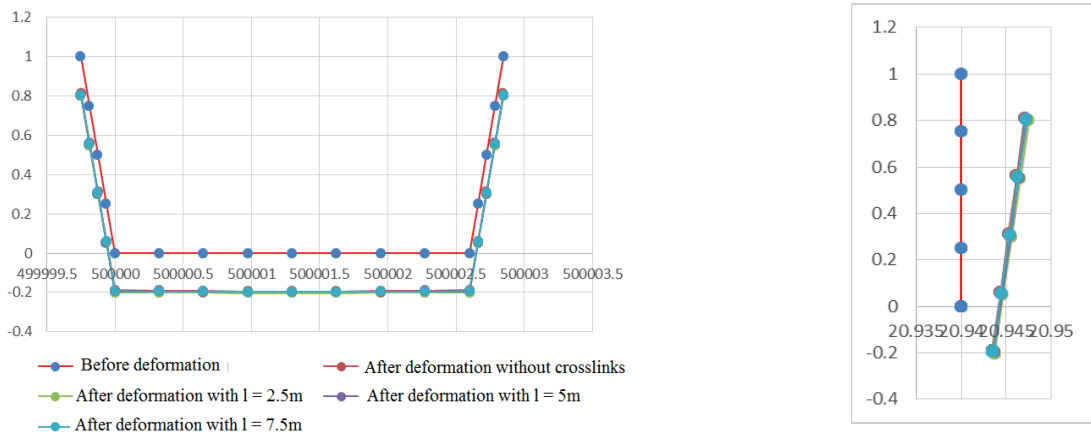

Figure 12. Deformation due to self-load: a) deformation in the y-z plane; b) deformation in the x direction

Figure 12 is the deformation diagram of the steel box girder cross-section caused by the self-load. Figure 12.a depicts the change in deformation in the y-z plane (opposite the x-axis view) as the crosslink spacing varies from 2.5m to 7.5m. Figure 12.b depicts the change in strain

in the cross-section's x-direction as the distance between the cross-links increases from 2.5m to 7.5m.

Figure 13 is the deformation diagram of the steel box girder cross-section due to symmetrical concentrated loads.

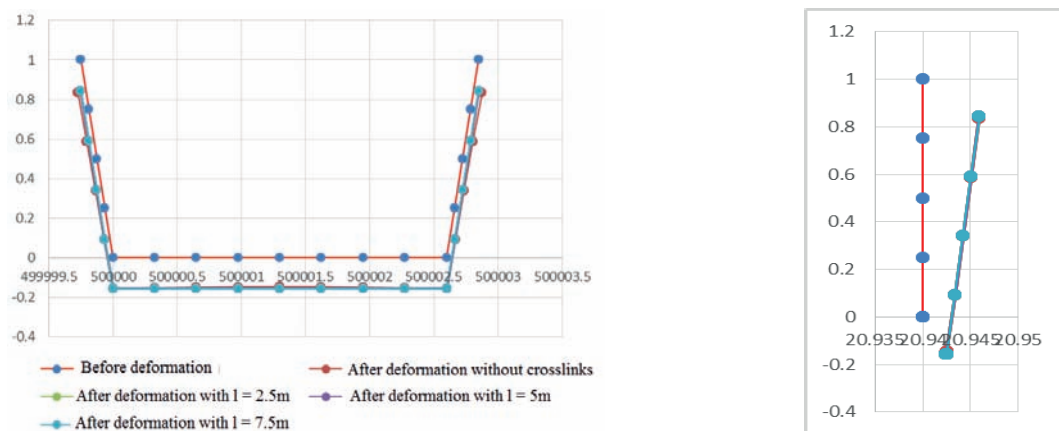

Figure 13. Cross-sectional deformation of steel box girder under symmetrical load: a) deformation in the y-z plane; b) deformation in the x direction

Figure 13.a shows the deformation change in the y-z plane (opposite of the x-axis view) when the crosslink distance varies from 2.5m to 7.5m. Figure 13.b demonstrates the change in strain in the x-direction of the cross-section when the cross-linking distance varies from 2.5m to 7.5m. When changing the cross-link distance of the

steel box girder, the cross-sectional deformation in the y-z plane and in the x direction does not change significantly. The deformation diagram of the steel box girder cross-section due to eccentric load is shown in Figure 14.

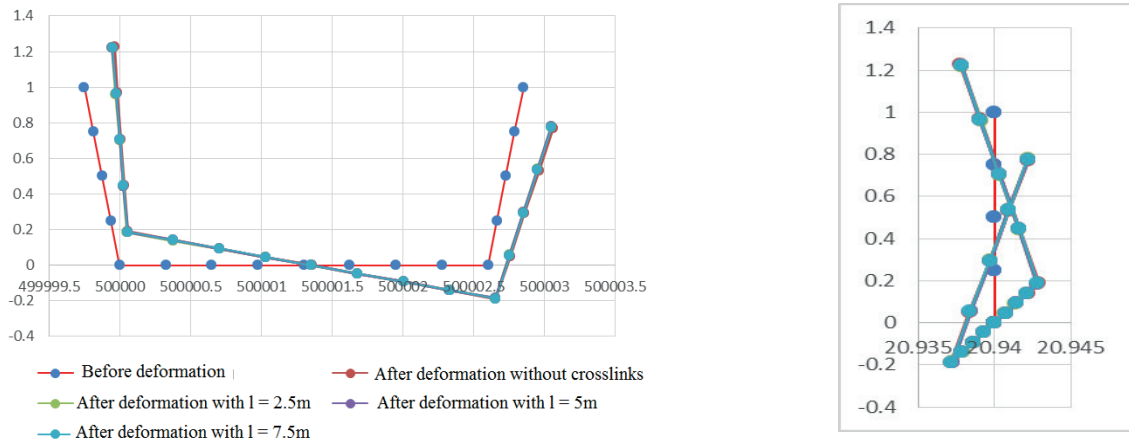

Figure 14. Cross-sectional deformation of steel box girder due to eccentric load: a) deformation in the y-z plane; b) deformation in the x direction

Figure 14.a shows how the deformation in the y-z plane (opposite the x-axis view) changes as the crosslink spacing varies from 2.5m to 7.5m. Figure 14.b depicts the x-direction strain change as the distance between the cross-links increases from 2.5m to 7.5m. The amount of deformation along the x-axis of the steel box girder cross-section depends greatly on the distance between the cross-beams.

Effects of types of longitudinal connection systems on steel box girder bridges on section warping.

Investigate the effect of longitudinal connections on cross-sectional warping in steel box girders. In this paper, we consider the cases where there is no bridge longitudinal linkage system, as well as type 1 (Figure 15.a) and type 2 (Figure 15.b) bridge longitudinal linkages.

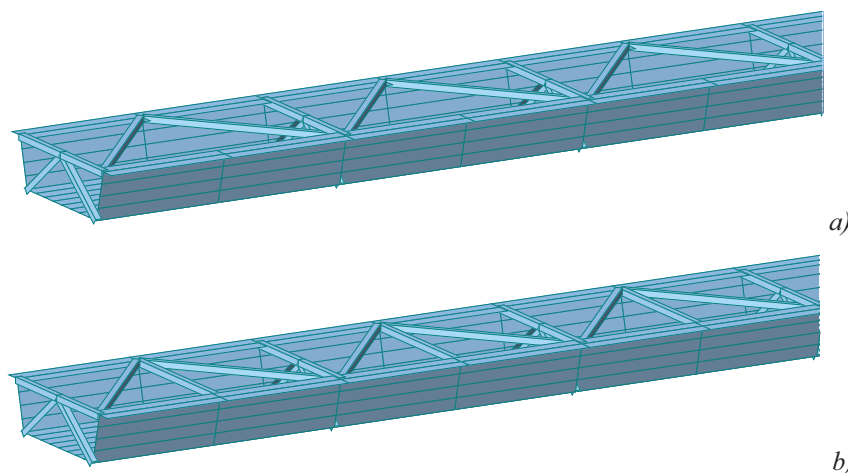

Figure 15. Model of steel box girder with bridge longitudinal connection system

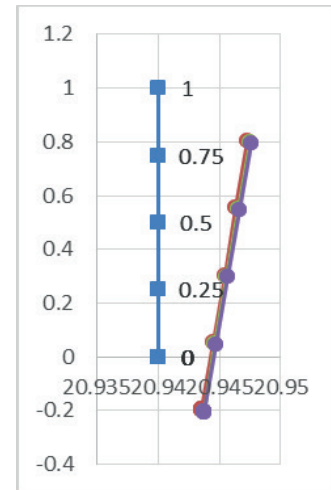
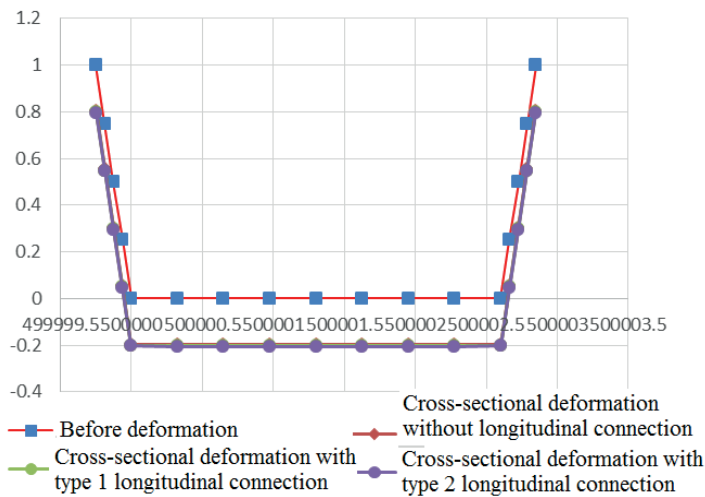

Figure 16. Deformation due to self-load: a) deformation in the y-z plane; b) deformation in the x direction

The self-load deformation diagram of the steel box beam cross-section is displayed in Figure 16. Figure 16.a illustrates how the strain has changed in the yx plane (the view direction is perpendicular to the x-axis), and Figure 16.b illustrates how the cross-section has changed and how the strain has changed in the x direction.

Figure 17 is the deformation diagram of the steel box beam cross-section due to symmetrical concentrated load. Figure 17.a shows the change in strain in the yx plane (view direction is opposite to the x axis), figure 17.b shows the change in strain in the x direction due to changing the cross section.

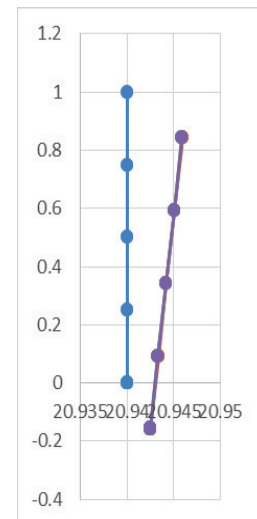
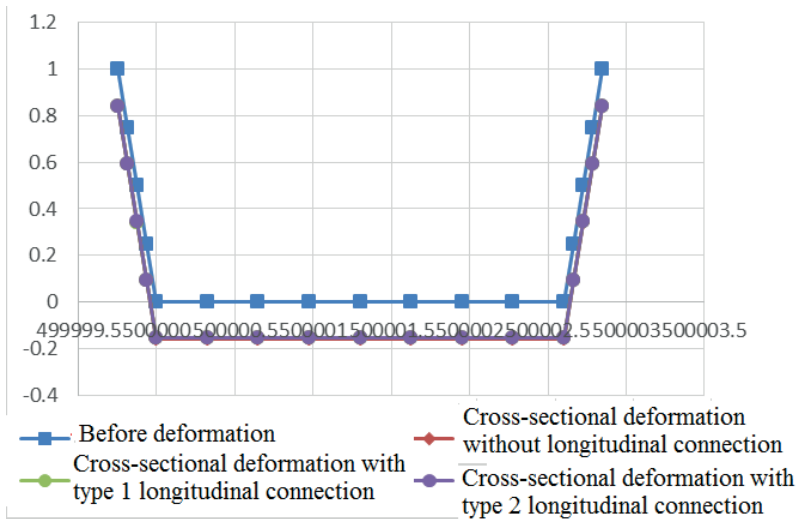

Figure 17. Deformation due to symmetrical loading: a) deformation in the yz plane; b) deformation in the x direction

Figure 18 shows the deformation diagram of the cross-section of a steel box beam due to eccentric loading causing torsion. Figure 18.a shows the change in strain in the yx plane (view

direction is opposite to the x axis), figure 18.b shows the change in strain in the x direction due to changing the cross section.

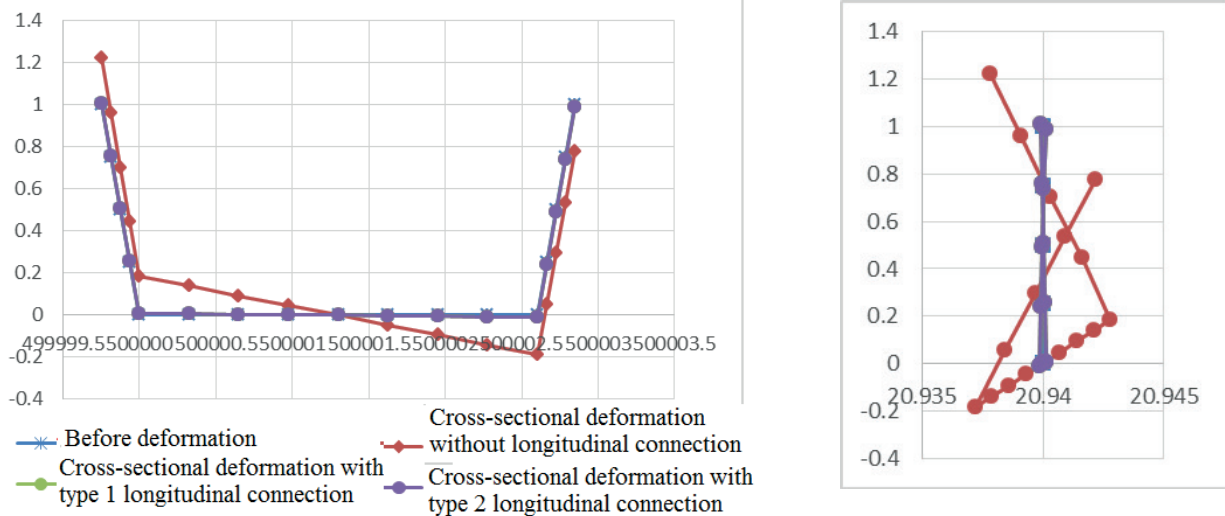

Figure 18. Deformation due to eccentric loading: a) deformation in the yz plane; b) deformation in the x direction

The findings displayed in the tables and graphics demonstrate how the longitudinal connection system affects warping deformation in steel box beams. It is evident how much more deformation can be prevented when the longitudinal connection system is used as opposed to not using a vertical linkage system.

CONCLUSION

Based on the research results obtained, the following conclusions can be drawn:

1. The internal forces and displacements in a steel box girder bridge structure are significantly affected by the warping effect, which arises due to torsional deformation. This effect alters the distribution of stresses and strains, potentially compromising the structural integrity and serviceability of the bridge over time.
2. To effectively reduce the warping effect in the cross-section of a steel box beam, it is essential to carefully select an appropriate B/H ratio, determine the optimal number of horizontal beams, and choose a suitable type of vertical connection based on structural requirements.
3. The findings of this study can serve as a valuable reference for the design and optimization of steel box girder bridges in Vietnam. However, to ensure structural safety

and long-term performance, the phenomenon of cross-sectional warping must be thoroughly evaluated and carefully incorporated into the design process.

REFERENCES

1. **Nguyen Huu Hung.** (2015). Research and analyze in detail the performance of curved steel box girder bridges. *Vietnam Transport Magazine*. Vol.9(3). Pp. 46-56.
2. **Dang Viet Duc.** (2021). analyses and investigations of torsional resistance on prestressed concrete continuous box girder bridges with horizontally curved alignment. *Transport and Communications Science Journal*. Vol 72(3). Pp. 356-368. <https://doi.org/10.47869/tcsj.72.3.10>
3. **Nguyen Viet Trung, Hoang Ha, Le Quang Hanh.** (2005). Steel bridge structure. Construction Publishing House, Hanoi, Vietnam.
4. **Todd Helwig, Joseph Yura, Reagan Herman, Eric Williamson, Dawei Li.** (2007). Design Guidelines for Steel Trapezoidal Box Girder Systems. *Texas Department of Transportation*.
5. **Donald, W. White et al.** (2012). Guidelines for Analysis Methods and

- Construction Engineering of Curved and Skewed Steel Girder Bridges. *Transportation Research Board, WASHINGTON, D.C.*
6. **Zakia B.** (2010). Analysis and Behavior Investigations of Box Girder Bridge. *M. Tech. thesis, Indian Institute of Technology Roorkee, India.*
 7. **Manjula R., Amrutha A.** (2021). Parametric analysis of single-cell box girder bridge. *IOP Conf. Series: Materials Science and Engineering, Vol. 1197(012047).* DOI 10.1088/1757-899X/1197/1/012047
 8. **Tauheed Reyaz, M.D., Syeda Nikhat Fathima.** (2018). Analysis and design of segmental box girder bridge. *International Research Journal of Engineering and Technology (IRJET).* Vol. 5(3). Pp. 1912-1919.
 9. **Sennah K.M., Kennedy J.B.** (2002). Literature review in analysis of box-girder bridges. *Journal of Structural Engineering ASCE.* Vol. 1061(10). Pp.1084-702. [https://doi.org/10.1061/\(ASCE\)10840702\(2002\)7:2\(134\)](https://doi.org/10.1061/(ASCE)10840702(2002)7:2(134))
 10. **Bien J., Kuzawa M., Kaminski T.** (2015). Validation of numerical models of concrete box bridges based on load test results. *Archives of Civil and Mechanical Engineering.* Vol.15. Pp. 1046-1060. 10.1016/j.acme.2015.05.007
 11. **Ayman M. Okeil, Sherif El-Tawil.** (2004). Warping Stresses in Curved Box Girder Bridges: Case Study. *Journal of Bridge Engineering.* Vol. 9(5). [https://doi.org/10.1061/\(ASCE\)1084-0702\(2004\)9:5\(487\)](https://doi.org/10.1061/(ASCE)1084-0702(2004)9:5(487))
 12. **Fernando A. Branco, Roger Green A.** (1985). Composite Box Girder Bridge Behavior During Construction. *Journal of Structural Engineering.* Vol. 111(3). [https://doi.org/10.1061/\(ASCE\)0733-9445\(1985\)111:3\(57\)](https://doi.org/10.1061/(ASCE)0733-9445(1985)111:3(57))
 13. **Ghani Razaqpur A., Hangang Li.** (1991). Thin-Walled Multicell Box-Girder Finite Element. *Journal of Structural Engineering.* Vol. 117(10). [https://doi.org/10.1061/\(ASCE\)0733-9445\(1991\)117:10\(295\)](https://doi.org/10.1061/(ASCE)0733-9445(1991)117:10(295))
 14. **Rajendra Thakai, Raghunath Deshpande, Shantinath Bedkihal.** (2016). Parametric study on behavior of box-girder bridges using finite element method. *International Research Journal of Engineering and Technology (IRJET).* Vol. 3(1). Pp. 211-218.
 15. **John B. Kennedy, Magdy Samnna, Khaled M. Sennah.** (2007). Dynamic analysis of curved continuous multiple-box girder bridges. *ASCE Journal of Bridge Engineering.* Vol.12. Pp.184-193.
 16. **Martin Alenius.** (2003). Finite element modelling of composite bridge stability. *MSc. Thesis , Department of Mechanics., Royale Institute of Technology.*
 17. Gupta P.K., Singh K K., Mishra A. (2010). Parametric study on behaviour of box-girder bridges using finite element method. *Asian journal of civil engineering.* Vol. 11(1). Pp. 135-148.
 18. **SAP2000.**(2012). Integrated software for structural analysis and design structural modelling and analysis. *LRFD; Bridge Design Practice.*
 19. **Ibrahim A., Salim H.** (2013). Finite-element analysis of reinforced-concrete box girder bridges under close-in detonation. *Journal of Structural Engineering ASCE,* No.10.1061, pp. 1943-5509. [https://doi.org/10.1061/\(ASCE\)CF.1943-5509.0000360](https://doi.org/10.1061/(ASCE)CF.1943-5509.0000360)
 20. **Zhang Y.H., Lin L.X.** (2014). Shear lag analysis of thin-walled box girders adopting additional deflection as generalized displacement. *Journal of Structural Engineering ASCE,* No.10.1061. Pp. 1943-7889. [https://doi.org/10.1061/\(ASCE\)EM.1943-7889.000070](https://doi.org/10.1061/(ASCE)EM.1943-7889.000070)

СПИСОК ЛИТЕРАТУРЫ

1. **Nguyen Huu Hung.** (2015). Research and analyze in detail the performance of curved

- steel box girder bridges // *Vietnam Transport Magazine*. Vol.9(3). Pp. 46-56.
2. **Dang Viet Duc.** (2021). analyses and investigations of torsional resistance on prestressed concrete continuous box girder bridges with horizontally curved alignment // *Transport and Communications Science Journal*. Vol 72(3). Pp. 356-368. <https://doi.org/10.47869/tcsj.72.3.10>
 3. **Nguyen Viet Trung, Hoang Ha, Le Quang Hanh.** (2005). Steel bridge structure // Construction Publishing House, Hanoi, Vietnam.
 4. **Todd Helwig, Joseph Yura, Reagan Herman, Eric Williamson, Dawei Li.** (2007). Design Guidelines for Steel Trapezoidal Box Girder Systems // *Texas Department of Transportation*.
 5. **Donald, W. White et al.** (2012). Guidelines for Analysis Methods and Construction Engineering of Curved and Skewed Steel Girder Bridges // *Transportation Research Board, WASHINGTON, D.C.*
 6. **Zakia B.** (2010). Analysis and Behavior Investigations of Box Girder Bridge // *M. Tech. Thesis, Indian Institute of Technology Roorkee, India.*
 7. **Manjula R., Amrutha A.** (2021). Parametric analysis of single-cell box girder bridge // *IOP Conf. Series: Materials Science and Engineering*, Vol. 1197(012047). DOI 10.1088/1757-899X/1197/1/012047
 8. **Tauheed Reyaz, M.D., Syeda Nikhat Fathima.** (2018). Analysis and design of segmental box girder bridge // *International Research Journal of Engineering and Technology (IRJET)*. Vol. 5(3). Pp. 1912-1919.
 9. **Sennah K.M., Kennedy J.B.** (2002). Literature review in analysis of box-girder bridges // *Journal of Structural Engineering ASCE*. Vol. 1061(10). Pp.1084-702. [https://doi.org/10.1061/\(ASCE\)10840702\(2002\)7:2\(134\)](https://doi.org/10.1061/(ASCE)10840702(2002)7:2(134))
 10. **Bien J., Kuzawa M., Kaminski T.** (2015). Validation of numerical models of concrete box bridges based on load test results // *Archives of Civil and Mechanical Engineering*. Vol.15. Pp. 1046-1060. 10.1016/j.acme.2015.05.007
 11. **Ayman M. Okeil, Sherif El-Tawil.** (2004). Warping Stresses in Curved Box Girder Bridges: Case Study // *Journal of Bridge Engineering*. Vol. 9(5). [https://doi.org/10.1061/\(ASCE\)1084-0702\(2004\)9:5\(487\)](https://doi.org/10.1061/(ASCE)1084-0702(2004)9:5(487))
 12. **Fernando A. Branco, Roger Green A.** (1985). Composite Box Girder Bridge Behavior During Construction // *Journal of Structural Engineering*. Vol. 111(3). [https://doi.org/10.1061/\(ASCE\)0733-9445\(1985\)111:3\(57\)](https://doi.org/10.1061/(ASCE)0733-9445(1985)111:3(57))
 13. **Ghani Razaqpur A., Hangang Li.** (1991). Thin-Walled Multicell Box-Girder Finite Element // *Journal of Structural Engineering*. Vol. 117(10). [https://doi.org/10.1061/\(ASCE\)0733-9445\(1991\)117:10\(295\)](https://doi.org/10.1061/(ASCE)0733-9445(1991)117:10(295))
 14. **Rajendra Thakai, Raghunath Deshpande, Shantinath Bedkihal.** (2016). Parametric study on behavior of box-girder bridges using finite element method // *International Research Journal of Engineering and Technology (IRJET)*. Vol. 3(1). Pp. 211-218.
 15. **John B. Kennedy, Magdy Samna, Khaled M. Sennah.** (2007). Dynamic analysis of curved continuous multiple-box girder bridges // *ASCE Journal of Bridge Engineering*. Vol.12. Pp.184-193.
 16. **Martin Alenius.** (2003). Finite element modelling of composite bridge stability // *MSc. Thesis , Department of Mechanics., Royale Institute of Technology.*
 17. **Gupta P.K., Singh K K., Mishra A.** (2010). Parametric study on behaviour of box-girder bridges using finite element method // *Asian journal of civil engineering*. Vol. 11(1). Pp. 135-148.
 18. **SAP2000.**(2012). Integrated software for structural analysis and design structural

- modelling and analysis // *LRFD; Bridge Design Practice*.
19. **Ibrahim A., Salim H.** (2013). Finite-element analysis of reinforced-concrete box girder bridges under close-in detonation // *Journal of Structural Engineering ASCE*, No.10.1061, pp. 1943-5509. [https://doi.org/10.1061/\(ASCE\)CF.1943-5509.0000360](https://doi.org/10.1061/(ASCE)CF.1943-5509.0000360)
20. **Zhang Y.H., Lin L.X.** (2014). Shear lag analysis of thin-walled box girders adopting additional deflection as generalized displacemen // *Journal of Structural Engineering ASCE*, No.10.1061. Pp. 1943-7889. [https://doi.org/10.1061/\(ASCE\)EM.1943-7889.000070](https://doi.org/10.1061/(ASCE)EM.1943-7889.000070)

Trong Chuc Nguyen — PhD, Lecturer and Researcher; Le Quy Don Technical University; 236 Hoang Quoc Viet Street, Hanoi, Vietnam; Scopus: 57214830825, ORCID: 0000-0001-9723-5161; trongchuc.nguyen@lqdtu.edu.vn

Нгуен Чонг Чык — кандидат технических наук, преподаватель-исследователь; Вьетнамский государственный технический университет имени Ле Куй Дона; Вьетнам, г. Ханой, ул. Хоанг Куок Вьет, д. 236; Scopus: 57214830825, ORCID: 0000-0001-9723-5161; trongchuc.nguyen@lqdtu.edu.vn

Ba Thang Phung — PhD, Lecturer and Researcher; University of Transport Technology, Hanoi 100000, Vietnam; thangpb@utt.edu.vn

Пхунг Ба Тханг — кандидат технических наук, преподаватель-исследователь; Университет транспортных технологий, Ханой 100000, Вьетнам.